



## SBZ 140 Profile machining centre

Profile machining centers



### Description

- 4-axis profile machining centre
- Designed for economical and efficient machining of aluminium and thin-walled steel profiles
- Standard version with air-cooled router spindle (version with water-cooled router spindle available optionally)
- All operations, such as routing, drilling and tapping, are performed while the profile bar is stationary to protect the profile surfaces
- Machining with all tools at angles continuously adjustable from  $-90^{\circ}$  to  $+90^{\circ}$
- Automatic clamp positioning with absolute measurement system
- The on-board tool magazine ensures that tool changing times are kept short, thereby optimizing machining cycles
- The magazine can be equipped with eight tools

- Up to two rotating angle heads with two different tools are optionally available for double-bar and end machining (0° - 90° - 180° - 270°) (optional)
- Two separate working zones enable machining in shuttle operation (optional). There is a central laser scanner on the operator's side to protect the area for maximum safety.
- 4-axis controller
- 18.5" colour display, USB ports and network connection
- Windows operating system
- eluCam

## Machining lengths

### SBZ 140 - 4.2 m

- Max. machining length with profile end machining, 4,200 mm
- Max. machining length without profile end machining, 4,320 mm

### SBZ 140 - 7.6 m

- Max. machining length with profile end machining, 7,600 mm
- Max. machining length without profile end machining, 7,720 mm

### SBZ 140 - 9.7 m

- Max. machining length with profile end machining, 9,700 mm
- Max. machining length without profile end machining, 9,820 mm

## Options

- Shuttle operation for working on two sides
- Automatic length measurement on both sides
- Clamping unit accommodates double profile machining
- Barcode scanner
- Stationary tool magazine (16x)
- On-board tool changers for angle head or saw head
- Angle routing heads
- Saw head
- Tool holders
- Collet chucks
- Collets

- Tools
- eluCad (office software package for optimised production management)

## Technical data

### SBZ 140

Max. machining length without profile end machining	4,320 mm, 7,720 mm, 9,820 mm
Max. machining length with profile end machining	4,200 mm, 7,600 mm, 9,700 mm
Traverse path X-axis	4,320 mm, 7,720 mm, 9,820 mm (additional lengths on request), Vmax. 63 m/min.
Traverse path Y-axis	845 mm, Vmax. 60 m/min.
Traverse path Z-axis	620 mm, Vmax. 60 m/min.
A-axis pivoting range	-90° 0° +90°
Spindle speed	max. 24,000 rpm
Spindle power output	11 kW S1
Direction of machining	top / front / rear / (left/right)
Positioning accuracy	0.1 mm/m
Tool holder	HSK-63F
Tool changing	Tool changer for eight tools, additional tool positions on request
Tool tray positions in the automatic magazine	8
Angle head	max. 2 (optional)
Disc milling cutter diameter	120 mm
Saw blade diameter	180 mm
Clamp positioning	automatic
Clamps	4 / 8 / 12 (max. 16)
Software	eluCam
Compressed air supply	> 7 bar
Power supply	400 V, 3~, 50 Hz, 63 A
Air consumption per minute	approx. 180 l/min. with spraying
Total length	approx. 7,700 mm, 11,240 mm, 13,390 mm
Depth	approx. 3,400 mm
Height	approx. 2,950 mm
Weight	approx. 5,000 kg / 7,400 kg / 8,200 kg

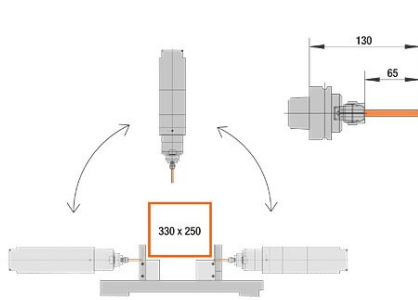

SBZ 140 Profile machining centre

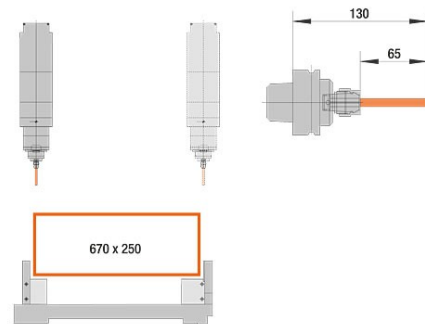

SBZ 140 Profile machining centre



SBZ 140 Profile machining centre

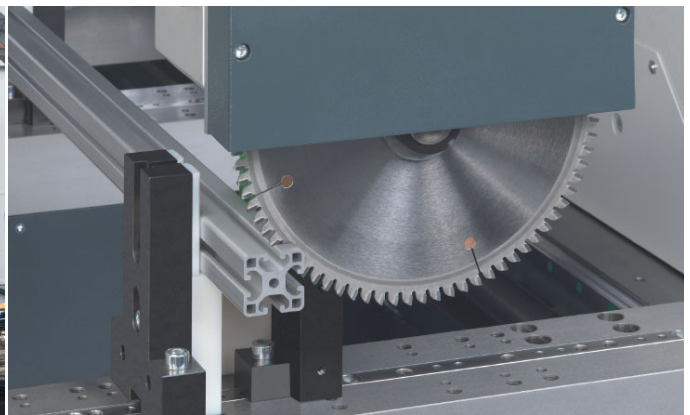

SBZ 140 Profile machining centre

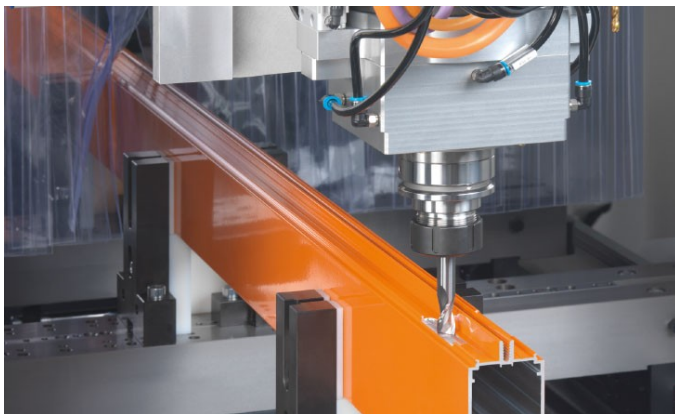

SBZ 140 Profile machining centre



SBZ 140 Profile machining centre



SBZ 140 Profile machining centre

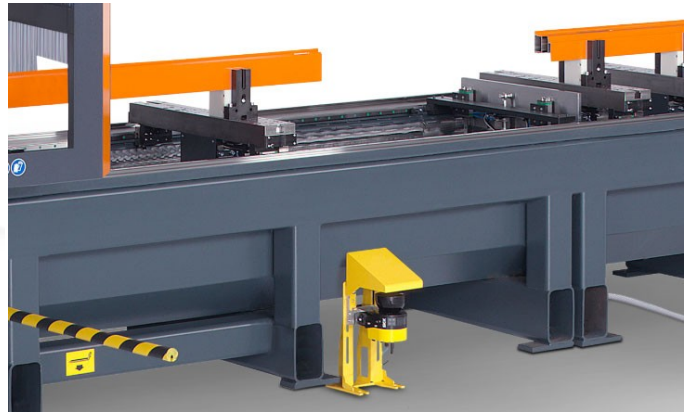

SBZ 140 Profile machining centre